

BALDOR® • RELIANCE 

Product Information Packet

ECR9254T

25HP,1770RPM,3PH,60HZ,284T,1072M,TEFC,F1

Part Detail							
Revision:	M	Status:	PRD/A	Change #:		Proprietary:	No
Type:	AC	Elec. Spec:	10WGZ352	CD Diagram:	CD0180	Mfg Plant:	
Mech. Spec:	10J907	Layout:	10LYJ907	Poles:	04	Created Date:	01-14-2015
Base:	RG	Eff. Date:	05-28-2019	Leads:	9#10		

Specs			
Catalog Number:	ECR9254T	Heater Indicator:	No Heater
Enclosure:	TEFC	Insulation Class:	F
Frame:	284T	Inverter Code:	Inverter Duty
Frame Material:	Iron	KVA Code:	G
Output @ Frequency:	25.000 HP @ 60 HZ	Lifting Lugs:	Standard Lifting Lugs
Synchronous Speed @ Frequency:	1800 RPM @ 60 HZ	Locked Bearing Indicator:	Locked Bearing
Voltage @ Frequency:	460.0 V @ 60 HZ	Motor Lead Quantity/Wire Size:	9 @ 10 AWG
	230.0 V @ 60 HZ	Motor Lead Exit:	Ko Box
XP Class and Group:	None	Motor Lead Termination:	Flying Leads
XP Division:	Not Applicable	Motor Type:	1072M
Agency Approvals:	CSA	Mounting Arrangement:	F1
	CSA EEV	Power Factor:	81
	UR	Product Family:	Super-E Chemical Processing
Auxillary Box:	No Auxillary Box	Pulley End Bearing Type:	Ball
Auxillary Box Lead Termination:	None	Pulley Face Code:	Standard
Base Indicator:	Rigid	Pulley Shaft Indicator:	Standard
Bearing Grease Type:	Polyrex EM (-20F +300F)	Rodent Screen:	None
Blower:	None	Shaft Extension Location:	Pulley End

Constant Torque Speed Range:	6	Shaft Ground Indicator:	No Shaft Grounding
Current @ Voltage:	68.000 A @ 208.0 V	Shaft Rotation:	Reversible
	62.000 A @ 230.0 V	Shaft Slinger Indicator:	Shaft Slinger
	31.000 A @ 460.0 V	Speed Code:	Single Speed
Design Code:	A	Motor Standards:	NEMA
Drip Cover:	No Drip Cover	Starting Method:	Direct on line
Duty Rating:	CONT	Thermal Device - Bearing:	None
Electrically Isolated Bearing:	Not Electrically Isolated	Thermal Device - Winding:	None
Feedback Device:	NO FEEDBACK	Vibration Sensor Indicator:	No Vibration Sensor
Front Face Code:	Standard	Winding Thermal 1:	None
Front Shaft Indicator:	None	Winding Thermal 2:	None

Nameplate NP3293													
CAT.NO.	ECR9254T			P/N				ENCLOSURE	TEFC				
SPEC.	10J907Z352G1		CC	010A		FRAME	284T		S/N				
HP	25		CLASS	F		HZ	60		DES	A			
RPM	1770		RPM MAX	2700		PH	3		KVA-CODE	G			
VOLT	230/460			I.P.	55								
AMP	62/31			SER.F.	1.25		PF	81		ODE BRG	6311	DE BRG	6312
RATING	40C AMB-CONT			NEMA-NOM-EFF	93.6		GREASE	POLYREX EM					
HTR-VOLTS			HTR-AMPS			HTR-WATTS			INV.TYPE				
SFA 76/38				C HP FR	60		C HP TO	90					
				CT HZ FROM	6		CT HZ TO	60					
				MOTOR WEIGHT	380		VT HZ FROM	6		VT HZ TO	60		

Parts List		
Part Number	Description	Quantity
SA292289	SA 10J907Z352G1	1.000 EA
RA278406	RA 10J907Z352G1	1.000 EA
09FN3001D02	EXTERNAL FAN, PLASTIC	1.000 EA
10CB1000A09P	KOBX, MACH W/1.50 NPT & PRIMER	1.000 EA
09GS1010	GASKET, DWG, LEADWIRE SEPERATOR	1.000 EA
10XN3118K16	5/16-18 X 1' GRADE #5, STL, ZINC PLATE	4.000 EA
HW1001A31	LOCKWASHER 5/16, ZINC PLT.591 OD, .319 I	4.000 EA
WD1000B16	T&B CX70TN OR L70P TERMINAL LUG	1.000 EA
10XN2520K06	1/4-20 X 3/8" HX HD SCREWGRADE 5, ZINC P	1.000 EA
HW1001A25	LOCKWASHER 1/4, ZINC PLT .493 OD, .255 I	1.000 EA
10XN3816K28	3/8-16 X 1.75 HEX HD CAP SCREW, GRADE 5	4.000 EA
HW1001A38	LOCKWASHER 3/8, ZINC PLT .688 OD, .382 I	4.000 EA
HW4600B41	V-RING SLINGER 2.125 X 2.880 X 0.280	1.000 EA
HA4017A11	1/8 X 2.75 GREASE EXT (F/S)	1.000 EA
HA4017A02	.125X2.50 GREASER EXTENS.F/S	1.000 EA
HW4019A01	PIPE COUPLING 1/8 NPT,STEEL,ZINC COATING	1.000 EA
HW4600B67	V-RING SLINGER 1.770 X 2.170 X .28 VITON	1.000 EA
HW5100A13	W4627-047 WVY WSHER	1.000 EA
10XN3118K36	5/16-18 X 2.25" HEX HD, GRADE 5	4.000 EA
10XN3118K44	5/16-18 X 2.75" HEX HD, GRADE 5	4.000 EA
10EP1108A01P	PULLEY ENDPLATE - 312 BRG.- ENCL., EPOXY	1.000 EA
10XN3816K28	3/8-16 X 1.75 HEX HD CAP SCREW, GRADE 5	4.000 EA
HW1001A38	LOCKWASHER 3/8, ZINC PLT .688 OD, .382 I	4.000 EA
10FH1007A24P	FAN COVER, MACH W/EPOXY PRIMER	1.000 EA

Parts List (continued)		
Part Number	Description	Quantity
10XN3118K20	5/16-18 X 1 1/4 GRADE 5 STEEL ZC PLATED	3.000 EA
HW1001A31	LOCKWASHER 5/16, ZINC PLT.591 OD, .319 I	3.000 EA
10CB1503A01P	CONDUIT BOX LIPPED LID, MACH W/EPXY PRMR	1.000 EA
14GS1003	GASKET CONDUIT BOX LID, NEOP	1.000 EA
10XN2520K16	1/4-20 X 1" HX HD SCRW GRADE 5, ZINC P	4.000 EA
HW1001A25	LOCKWASHER 1/4, ZINC PLT .493 OD, .255 I	4.000 EA
HW2501H28	KEY, 1/2 SQ X 3.250	1.000 EA
MJ5001A27	32220KN GRAY SEALER *MIN BUY 4 QTS=1GAL	0.031 QT
MJ5001A14	DYNAPRO SEALANT, CP MTR VC#2508050 (603	0.026 EA
MJ5002A01	SILICON RUBBER SEALANT, 732CL 10.3 OZ TU	0.025 EA
LB1115N	LABEL,LIFTING DEVICE (ON ROLLS)	1.000 EA
10EP1110A06PP44	FREP, MACH W/PRIMER & MG1025G96	1.000 EA
HW4500A21	1618BALEMITE FITTING 825 UNIVERSAL	1.000 EA
HA4051A00	PLASTIC CAP FOR GREASE FITTING	1.000 EA
HW4500A17	317400 ALEMITE GREASE RELIEF	1.000 EA
HA4054	SHORT T-DRAIN FITTING, .125" N.P.T.	1.000 EA
MJ1000A02	GREASE, MOBIL POLYREX EM - 124047	0.130 LB
HW4500A17	317400 ALEMITE GREASE RELIEF	1.000 EA
HW4500A03	GREASE FITTING, .125 NPT 1610(ALEMITE) 8	1.000 EA
HA4051A00	PLASTIC CAP FOR GREASE FITTING	1.000 EA
HA4054	SHORT T-DRAIN FITTING, .125" N.P.T.	1.000 EA
HW2500A25	WOODRUFF KEY USA #1008 #BLOW CARBON STEE	1.000 EA
51XB1214A20	12-14X1.25 HXWSSLD SERTYB	1.000 EA
MG1025G96	WILKOFAS SG, 779.7048, MOUSE GRAY #7048	0.070 GA

Product Information Packet: ECR9254T - 25HP,1770RPM,3PH,60HZ,284T,1072M,TEFC,F1

85XU0407S04	4X1/4 U DRIVE PIN STAINLESS	2.000 EA
LB1002N	LABEL,MARINE DUTY (ON ROLLS)	1.000 EA
LB1119N	WARNING LABEL	1.000 EA
LC0181	CONNECTION LABEL	1.000 EA
NP3293	SS CRUSHER DUTY INV UL CSA-EEV PREM CC	1.000 EA
10PA1000	PACKAGING GROUP COMBINED PRINT PK1023A06	1.000 EA
MN416A01	TAG-INSTAL-MAINT no wire (1200/bx) 3/19	1.000 EA

AC Induction Motor Performance Data

Record # 50324 - Typical performance - not guaranteed values

Winding: 10WGZ352-R001	Type: 1072M	Enclosure: TEFC
-------------------------------	--------------------	------------------------

Nameplate Data				460 V, 60 Hz: High Voltage Connection	
Rated Output (HP)	25			Full Load Torque	73.8 LB-FT
Volts	230/460			Start Configuration	direct on line
Full Load Amps	62/31			Breakdown Torque	208 LB-FT
R.P.M.	1770			Pull-up Torque	133 LB-FT
Hz	60	Phase	3	Locked-rotor Torque	187 LB-FT
NEMA Design Code	A	KVA Code	G	Starting Current	188 A
Service Factor (S.F.)	1.25			No-load Current	12.5 A
NEMA Nom. Eff.	93.6	Power Factor	81	Line-line Res. @ 25°C	0.26065 Ω
Rating - Duty	40C AMB-CONT			Temp. Rise @ Rated Load	51°C
S.F. Amps	76/38			Temp. Rise @ S.F. Load	70°C
				Locked-rotor Power Factor	34.7

Load Characteristics 460 V, 60 Hz, 25 HP

% of Rated Load	25	50	75	100	125	150	S.F.
Power Factor	45	67	77	81	83	83	83
Efficiency	90	93.5	94.1	93.8	93.2	92.3	93.2
Speed	1793.1	1787.4	1781.1	1773.7	1766.2	1757.2	1766
Line amperes	14.3	18.5	24.1	30.6	37.7	45.7	37.7

Performance Graph at 460V, 60Hz, 25.0HP Typical performance - Not guaranteed values

ABB Motors and Mechanical Inc.

WINDING # 10WGZ352

Typical performance - not guaranteed values.

25 HP 3 PH 60 HZ 1770 RPM 460 V 1072M

TORQUES(LB-FT): PO=208 PU=133 LR=187 LRA=188

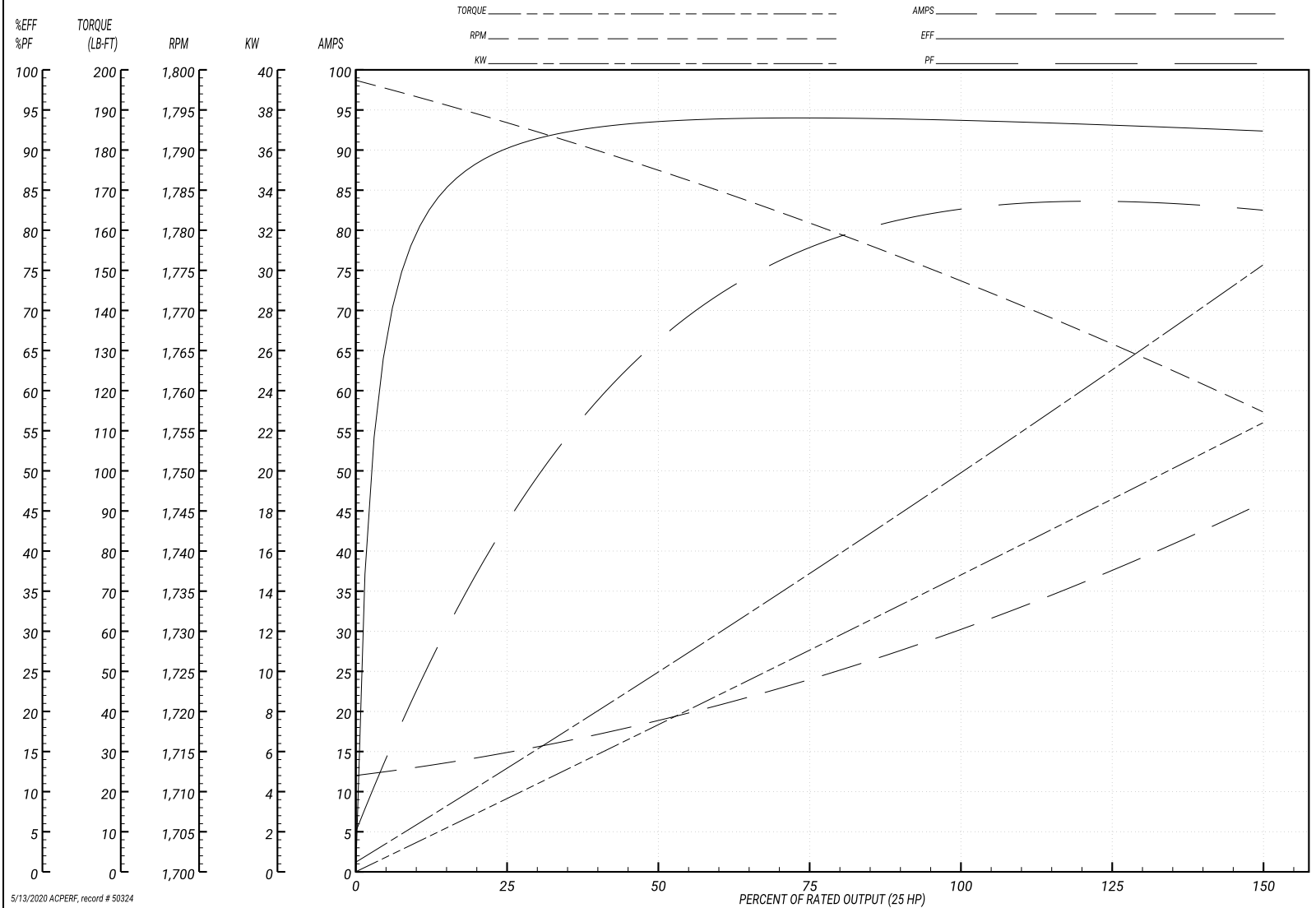

5/13/2020 ACPERF, record # 50324

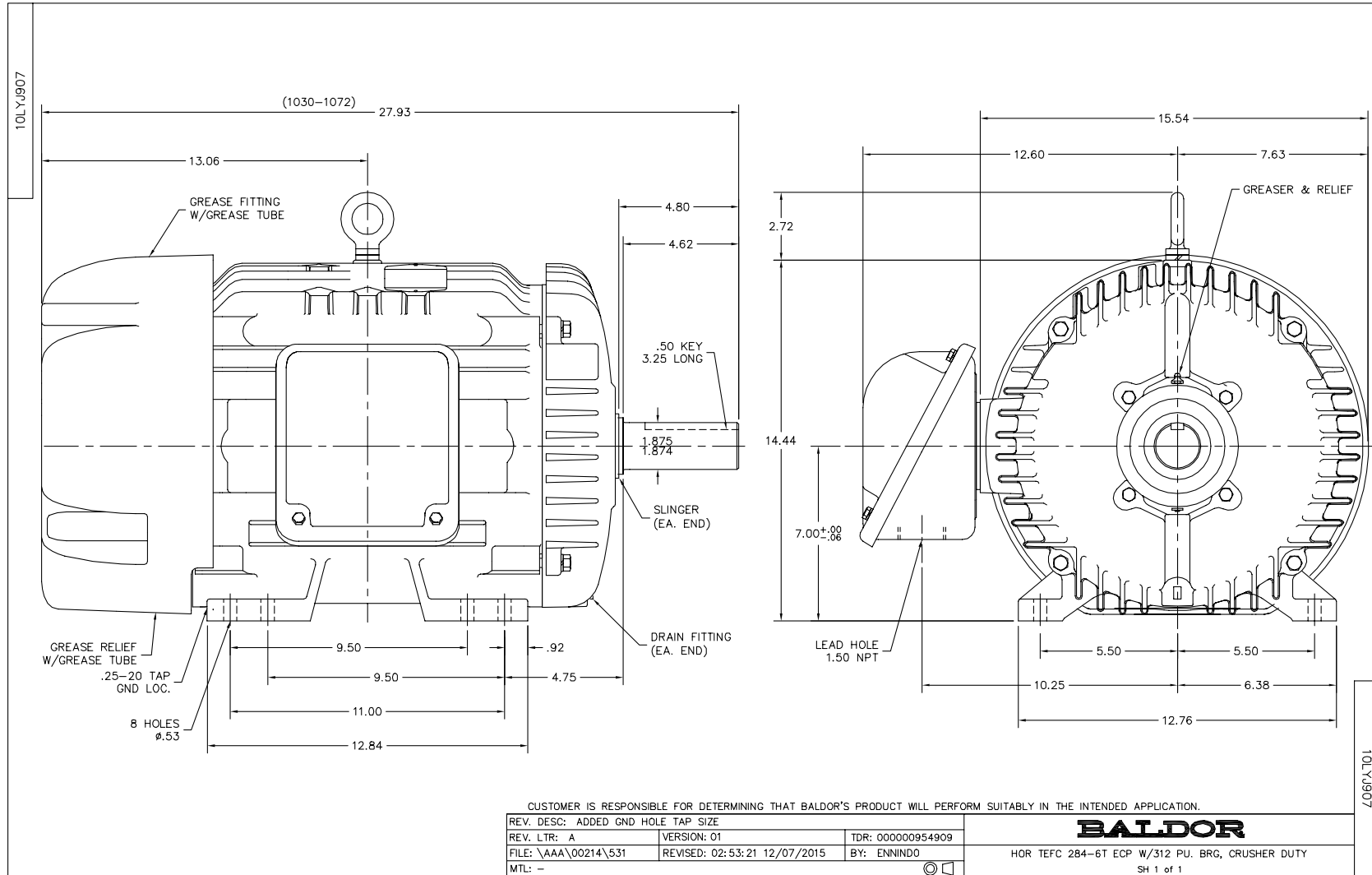

CD0180



LOW VOLTAGE
(2D)



HIGH VOLTAGE
(1D)



NOTES:

1. INTERCHANGE ANY TWO LINE LEADS TO REVERSE ROTATION.
2. OPTIONAL THERMOSTATS ARE PROVIDED WHEN SPECIFIED.
3. ACTUAL NUMBER OF INTERNAL PARALLEL CIRCUITS MAY BE A MULTIPLE OF THOSE SHOWN ABOVE.
4. LEAD COLORS ARE OPTIONAL. LEADS MUST ALWAYS BE NUMBERED AS SHOWN.

CD0180

REV. DESC: ADD CLASS CONN00000007		
REV. LTR: D	VERSION: 01	TDR: 000001099922
FILE: \AAA\00005\148	REVISED: 10:25:29 02/19/2019	BY: ENBRIRO
MTL: -	© □	

BALDOR - RELIANCE®

3PH, DV, 9 LEADS, DELTA CONNECTION

SH 1 of 1

Marketing maintained PDF of MN416:

[MN416?ManNumber=MN416](#)